



DUGARD EAGLE **BRIDGE MILL**

3 Axis Bridge Type Machining Centre

Large capacity, ease of operation with powerful cutting capability.



3 Axis Bridge Type



SDV-H Series Bridge Type Machining Centre

- Linear ways on X, Y, Z axes.
- Exclusive 4 linear ways on Z axis (patented).
- Exclusive SRG 65 roller type linear ways on Y axis increases rigidity by 50% compared to conventional construction.
- Ladder design of beam provides 25% higher structural rigidity than conventional parallel sideways.
- Increased distance between columns is available upon request.
- Fully enclosed splash guard.
- Choice of Fanuc, Siemens or Heidenhain controls.



Machining Centre

SDV Series

Bridge Type Machining Centre

- Box way on X axis.
- Linear ways on Y and Z axes.
- Two linear ways on Z axis.
- Table width over 2200 mm will be supported by 3 linear ways.
- Ladder design of beam provides 25% higher structural rigidity than conventional parallel slideways.
- Greater span between columns increases stability by 30% compared to conventional frame construction.
- Increased distance between columns is available upon request.
- Fully enclosed splash guard.
- Choice of Fanuc, Siemens or Heidenhain controls.





Eagle Bridge

Make Complex Mo



Now, you can have the correct bridge type machining centre with quality features to handle precision mould machining efficiently. Eagle bridge type machining centres are designed and built to help mould makers stay competitive.

Type Machining Centres

ould Machining Simple



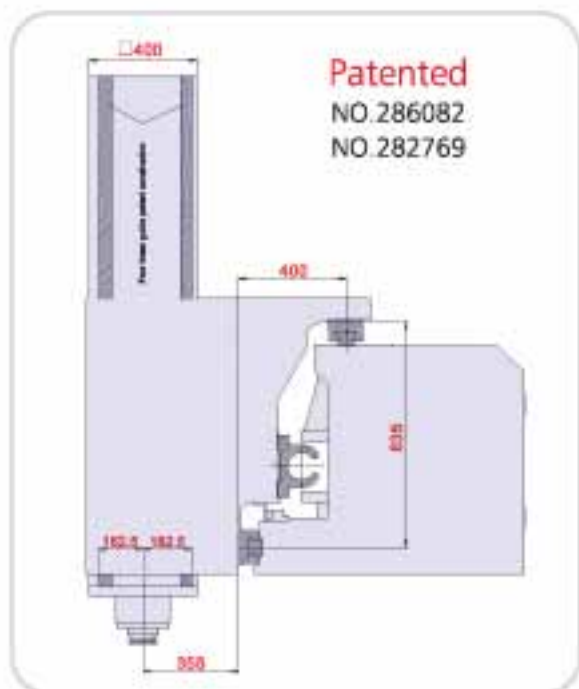

SDV-H Series

Rugged Construction on Y and Z axes

- Distance from spindle center to Y axis slide blocks is only 355 mm.
- 4 linear ways on spindle head sideways. (patented)
- Extra wide span between two linear, ways on Y axis is 400 mm.

Choice of Box Ways or Linear Ways on Z axis

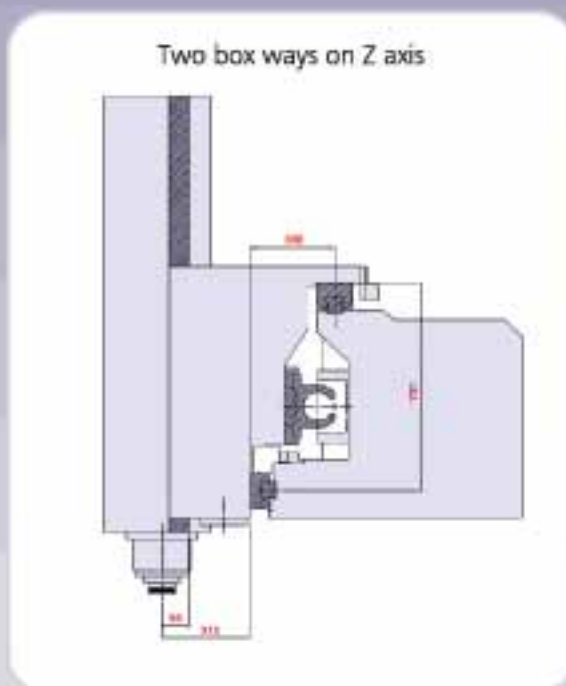
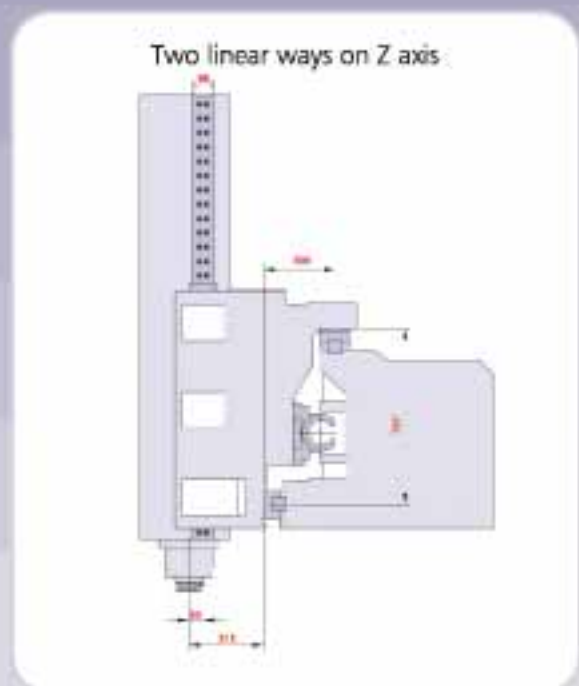

SDV Series

Rugged Construction on Y and Z axes

- Distance from spindle center to Y axis slide blocks is only 315 mm.
- Distance from spindle center to Z axis linear ways is only 95 mm.
- Extra big span between two linear ways on Y axis is 300 mm.

Spindles for SDV-H Series.

High/Low Speed Gear Box



Gear-drive Spindle

The spindle is driven by a high torque, high horsepower servo motor and transmitted through a gear box with high / low speed ranges.



Built-in Type Spindle

The low speed range provides high torque output, making the machine ideal for heavy cutting. The high speed range is suitable for high speed machining with fine surface finish.

Various Spindles to Choose from

Spindle Taper	Transmission	Spindle speeds
BT-50	Germany zF gearbox	4000, 6000, 8000 RPM
BT-50	Built-in motor	10,000 RPM
HSK-A63		12000–24000 RPM

Spindles for SDV Series.

High Precision, High Torque Spindle

High Precision Spindle Construction



Gear-drive Spindle

All spindles run on class P4 large diameter precision bearings for outstanding running performance and long service life.



Gear-drive Spindle

- 4,000 or 6,000 RPM Spindle Speed
- The spindle is driven by a Germany ZF gearbox, providing high/low speed ranges.

Choice of Transmission shafts (optional)

The SDV series machine is available to use two types of transmission shafts according to machining requirement.

Superior Rigidity Unparalleled Stability

Perfect Structure Design for Guaranteed
Machining Performance

- The structural parts, such as the machine bed table, double columns and beam are manufactured from meehanite cast iron, heavy rib reinforced and stress relieved. This results in minimum vibration and increased structural rigidity and stability.
- Box type columns are heavily constructed with wide span between columns, making the machine ideal for large part machining.
- X axis is fully supported throughout its entire travel without overhang problem.

Patented



Exclusive 4 Linear Ways on Z axis

The spindle head moves on exclusively designed 4 SRG 45 roller type linear ways. The results are greatly increased rigidity and stability, vibration free during heavy cutting and improved surface finish.



Heavily Constructed Base

The base is manufactured from meehanite cast iron with heavily reinforced ribbing, tempered and stress relieved to guaranteed to be deformation free after many years of service.



Three Linear Ways on Base

The base is equipped with three extra heavy duty roller type linear ways to resist heavy load without deformation. Greater span between linear ways upgrades the rigidity of base.

Dual Chip Augers on Base

These are two chip augers provided on right and left side of the base.

These chip augers deliver chips to chain type chip conveyor for collection by a chip tank.

Chip augers at each side of the base provide rapid and efficient cleaning.

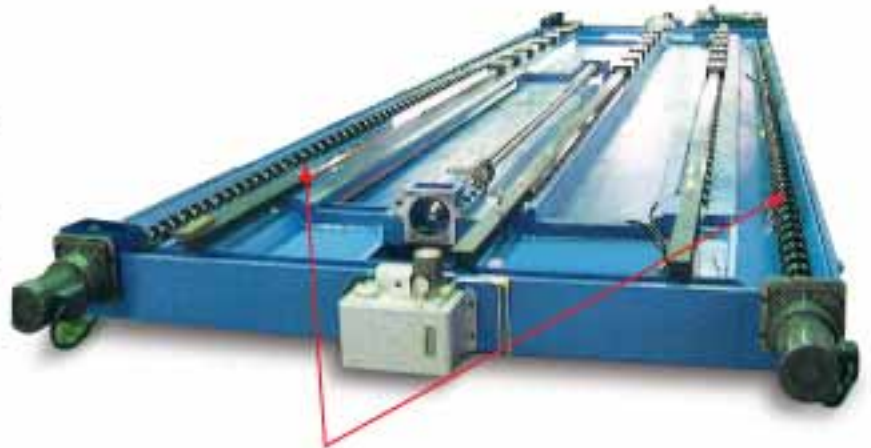

Chip Augers



Ladder Type Beam Design

- Linear ways on Y axis are supported by a "ladder" structure to increase stability of the spindle head when performing heavy cutting.
- Distance between two linear ways on Y axis is 400 mm (SDV-H Series), and 300 mm (SDV Series).

Heavy Duty Linear Ways Provide **50%** Extra Rigidity

For rigidity on horizontal and vertical movements, the patented. SRG 65 roller type linear ways on Y axis provide 50% higher rigidity than conventional Structure.



Electric Control Meets CE Standards

- The control circuit consists of high quality electronic components for maximum dependability of control and long service life.
- The control circuit is well planned for easy maintenance.

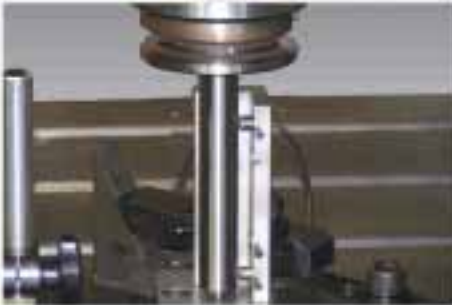

Spindle Thermal Compensation System (Optional)

- Keeps spindle displacement within 0.03 mm
- Thermal compensation sensors are equipped at spindle head, beam and ZF gear box support to detect the temperature variation.



Coolant Through Spindle System (CTS) Available as 20 or 70 bar options

The coolant through spindle system delivers high pressure coolant to cutting area. This avoids thermal effects on workpiece and cutting tool, while providing better surface finish.



Renishaw TS-27R and NC4 Tool Length And Diameter Measuring Equipment (Optional)

- The sophisticated tool length and diameter measuring equipment provides automatic tool measurement, ensuring dependable machining accuracy.
- The tool measuring equipment also allows for detection for tool breakage.



OMP60 Touch Probe (Optional)

This touch probe is applied for checking workpiece sizes and position.

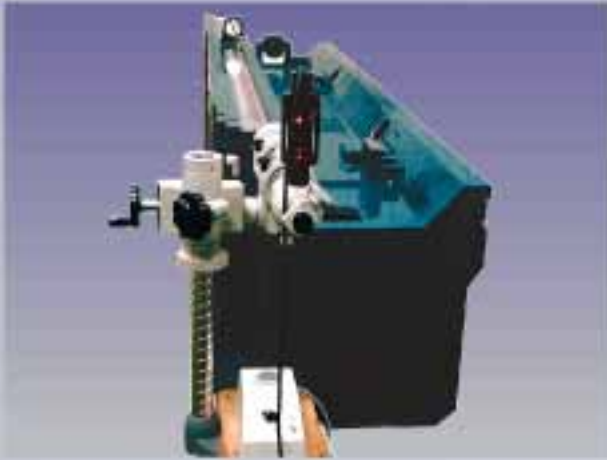

High Precision Ball Screws on 3 Axes

- High precision class C3 ball screws are used for all three axes.
- Precise pre-tension is applied to the ball screws. Both backlash and pitch errors are compensated by laser calibration equipment.



Convenient Workpiece Loading / Unloading

Ease of loading and unloading for the work is made simple due to the additional doors on the operator side of the machine and the vertical splash guards at the front.



Advanced Automatic Lubrication System

- When a preset pressure is reached, the lubrication points releases lubricant simultaneously, controlled by a pressure feedback system.
- Oil leakage or blockage is detected for added convenience of maintenance.

Eagle Bridge Type Machining Centre

Provides pendant type and
stand supported type control
box to choose from.



Stand Supported
Control Box (Standard)

Pendant
Control Box (Standard)

The pendant control box with a MPG hand wheel
provides easier operation and adjustment for the
operator.



Spindle Oil Cooler

The spindle oil cooler keeps the spindle at a
constant temperature at all times during high
speed machining.

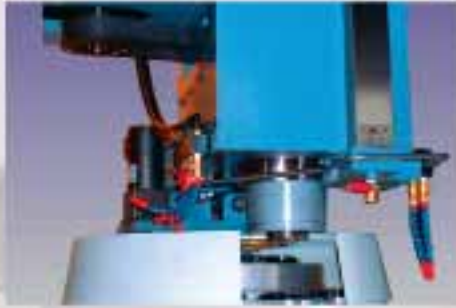

16 Tools Drum Type Magazine (For SDV Series only)

- The drum type magazine accommodates various types of tool shanks, such as ISO 50(40), BT-50, CAT-50, DIN 69871 (BT-40, CAT-40).
- The Bi-directional, random tool selection allows for fast tool changes in under 5 seconds, tool to tool.



32, 40, 60 Tools Side-Mount Chain Type Magazine

- The chain type magazine is side mounted to prevent contamination from chips or coolant.
- The Bi-directional, random tool selection allows for fast tool changes in under 5 seconds, tool to tool.
- The auto door on the ATC magazine provides protection for the tools from chips and dust.

Rigorous Inspection



Laser Calibration

After assembly, all machines are measured and calibrated using state-of-the-art laser calibration equipment. This ensures precise verification and compensation of the machines axes resulting in increased accuracy and repeatability.

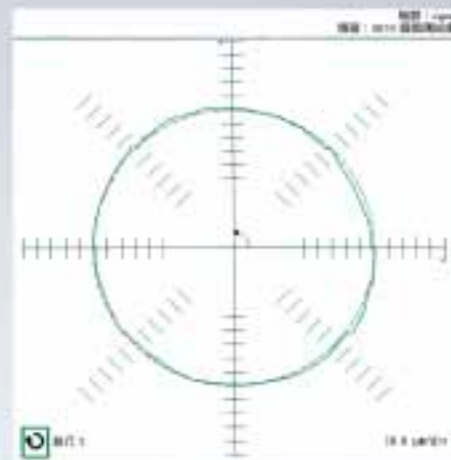

Ball Bar Testing

The test is carried out using a precision test bar which outputs micron changes in length. The bar is fixed to the spindle and table. The machine is then put through a series of circular moves in the x/y plane, and 1/2 circle moves in the x/z and y/z planes. Encoder data from the bar is fed into a computer, which outputs a chart of machine accuracy. Any deviations in squareness or length show up as distorted circles that are very easy for a technician to spot. This chart assures that the machine is accurate and properly aligned.

SDV-H Series Machine Dimensions

Unit:mm

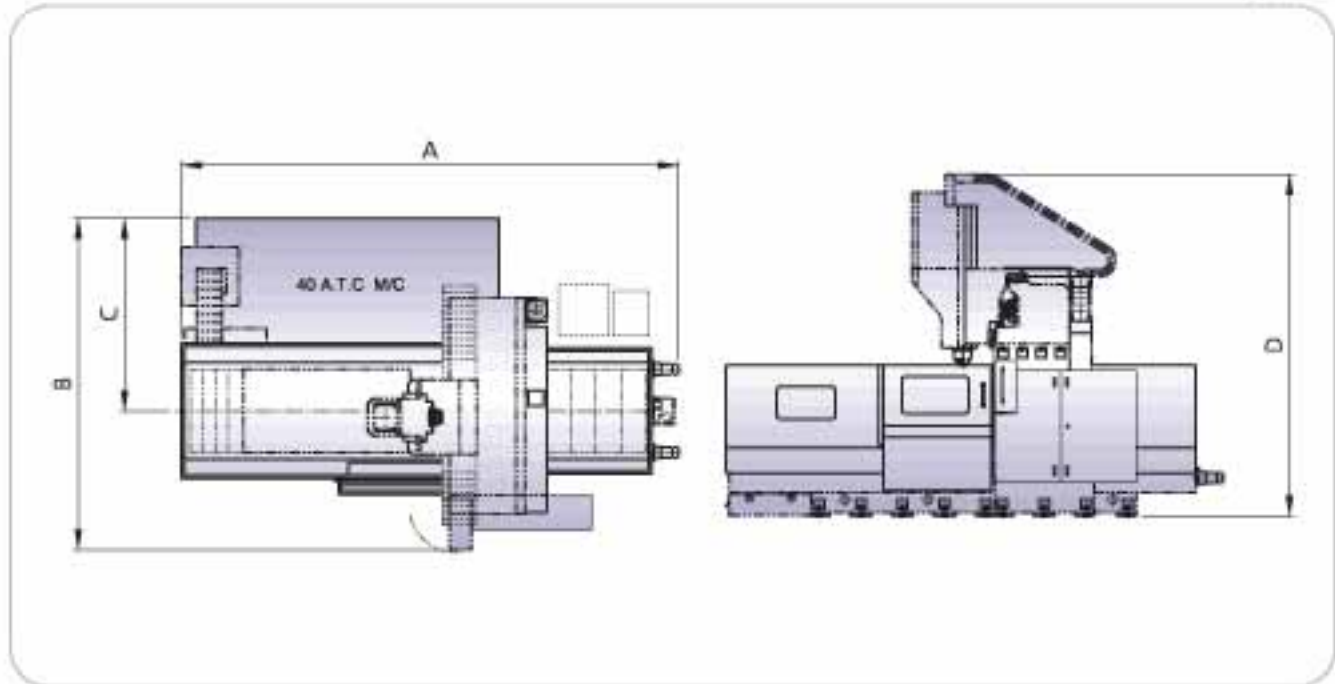

SDV-H Series Machine Dimensions

Unit:mm

MODEL	Distance Between Columns	A	B	C	D
SDV-1611H	1200	5210	3985	2315	4355(z:760)
SDV-2011H	1200	5970	3985	2315	4355(z:760)
SDV-2215H	1600	6210	5165	2515	4250(z:760) 4830(z:1000)
SDV-3215H	1600	8210	5165	2515	4250(z:760) 4830(z:1000)
SDV-2219H	2000	6270	5565	2715	4250(z:760) 4830(z:1000)
SDV-3219H	2000	8270	5565	2715	4250(z:760) 4830(z:1000)
SDV-4219H	2000	10270	5565	2715	4250(z:760) 4830(z:1000)
SDV-3224H	2500	8270	6065	2965	4250(z:760) 4830(z:1000)
SDV-4224H	2500	10270	6065	2965	4250(z:760) 4830(z:1000)
SDV-5224H	2500	12270	6065	2965	4250(z:760) 4830(z:1000)
SDV-5229H	3000	12270	6565	3215	4250(z:760) 4830(z:1000)
SDV-6229H	3000	14270	6565	3215	4250(z:760) 4830(z:1000)

SDV Series Machine Dimensions

Unit:mm

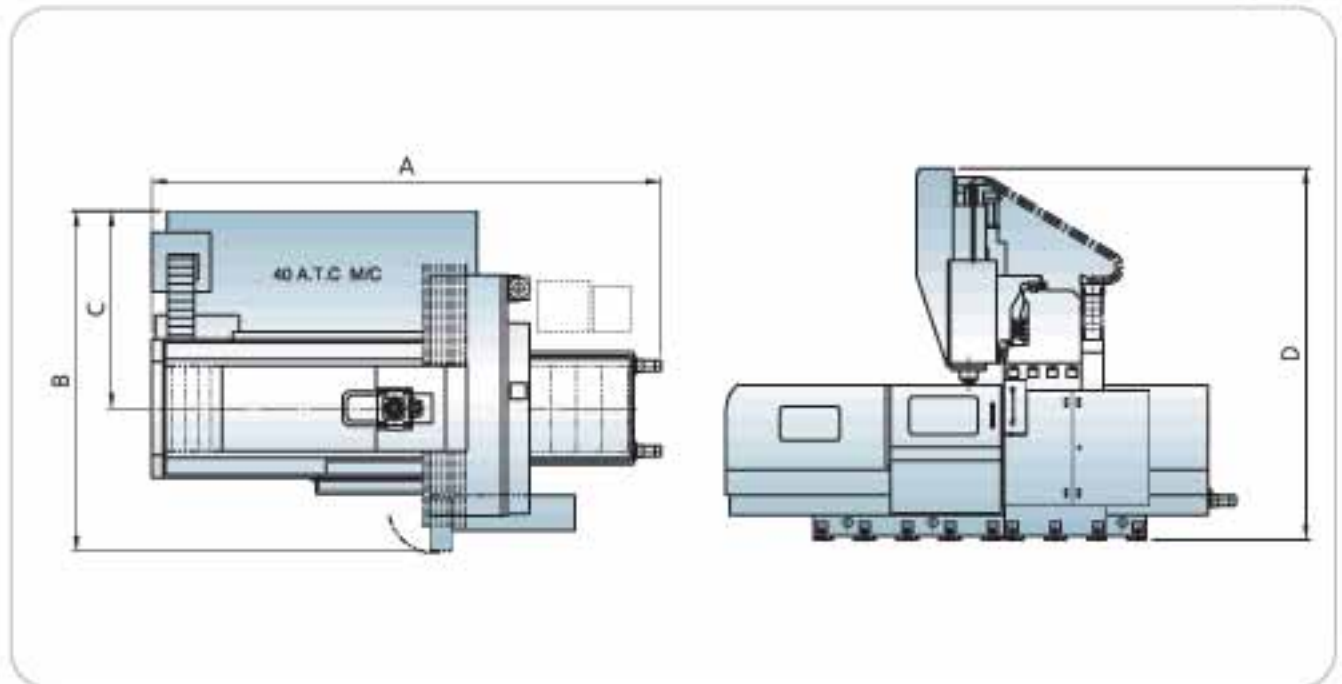

SDV Series Machine Dimensions

Unit:mm

MODEL	Distance Between Columns	A	B	C	D
SDV-1611	1200	5210	3985	2315	4105(z:760)
SDV-2011	1200	5970	3985	2315	4105(z:760)
SDV-2215	1600	6210	4385	2515	4105(z:760) 4735(z:1000)
SDV-3215	1600	8210	4385	2515	4105(z:760) 4735(z:1000)
SDV-2219	2000	6270	5565	2715	4000(z:760) 4630(z:1000)
SDV-3219	2000	8270	5565	2715	4000(z:760) 4630(z:1000)
SDV-4219	2000	10270	5565	2715	4000(z:760) 4630(z:1000)
SDV-3224	2500	8270	6065	2965	4000(z:760) 4630(z:1000)
SDV-4224	2500	10270	6065	2965	4000(z:760) 4630(z:1000)
SDV-5224	2500	12270	6065	2965	4000(z:760) 4630(z:1000)
SDV-5229	3000	12270	6565	3215	4250(z:760) 4830(z:1000)
SDV-6229	3000	14270	6565	3215	4000(z:760) 4630(z:1000)

Machine Specifications

SDV-H Series

Item	Model	Unit	SDV-1811H	SDV-2011H	SDV-2215H	SDV-2219H	SDV-3215H	SDV-3219H
X-AXIS TRAVEL		mm	1600	2040	2200	2200	3200	3200
Y-AXIS TRAVEL		mm	1100	1100	1500	1900	1500	1900
Z-AXIS TRAVEL		mm	760			760(1000)		
TABLE SIZE		mm	1600x1000	2000x1000	2000x1400	2000x1700	3000x1400	3000x1700
T-SLOTS DIMENSION		mm	22(24, 28)					
TABLE LOAD CAPACITY		kgs	3000	3500	5000	5000	7000	8000
DISTANCE BETWEEN COLUMNS		mm	1200	1200	1600	2000	1600	2000
DISTANCE FROM SPINDLE NOSE TO TABLE		mm	250-1010 / 355-1115		165-925(165-1165) / 270-1030(270-1270)			
SPINDLE TAPER TOOL SHANK			ISO NO. 50(40) BT-50, CAT-50, DIN 69871 (BT-40, CAT-40), HSK-A63					
SPINDLE SPEED RANGE		rpm	20-4000(30-6000)(100-10000)(80-8000)(12000-24000)					
MAIN MOTOR OUTPUT (30MIN RATING/CONT.)		HP	30/25(35/30)					
RAPID TRAVERSE RATE X, Y-AXIS		mm/min	15000(20000)			12000(15000)		
RAPID TRAVERSE RATE Z-AXIS		mm/min	12000(15000)					
CUTTING FEED RATE		mm/min	1-5000(1-8000)					
MINIMUM INPUT INCREMENT		mm/min	0.001					
TOOL MAGAZINE CAPACITY		pcs	(20/32/40)					
MAX, TOOL DIAMETER /ADJACENT POCKETS EMPTY		mm	Ø125 / Ø210					
MAX, TOOL LENGTH (FROM GAUGE LINE)		mm	350					
MAX, TOOL WEIGHT		kgs	(18/20)					
TOOL SELECTION METHOD			(ABS - Random Bl)					
TOOL CHANGE TIME (T-T)(APPROX.)		sec.	8(4.5)					
POWER REQUIREMENT		Kva	40(45)					
FLOOR SPACE REQUIREMENT		mm	6300x4800	7000x4800	7100x5200	7100x5700	9400x5200	9400x5700
MACHINE HEIGHT FROM FLOOR LEVEL		mm	4355					
MACHINE WEIGHT (APPROX.)		kgs	17500	18300	22300	26000	25300	31000
CNC CONTROLLER		mm	Fanuc, Meidas, Siemens, Heidenhain Series etc.					
POSITIONING ACCURACY		mm	JIS B6338 0.01/300, VDI 3441 P0.025					
REPEATABILITY ACCURACY		mm	± 0.003					

• The above specifications are subject to change without prior notice.

SDV Series

Item	Model	Unit	SDV-1611	SDV-2011	SDV-2215	SDV-2219	SDV-3215	SDV-3219
X-AXIS TRAVEL		mm	1600	2040	2200	2200	3200	3200
Y-AXIS TRAVEL		mm	1100	1100	1500	1900	1500	1900
Z-AXIS TRAVEL		mm	760			760(1000)		
TABLE SIZE		mm	1600x1000	2000x1000	2000x1400	2000x1700	3000x1400	3000x1700
T-SLOTS DIMENSION		mm	22(24, 28)					
TABLE LOAD CAPACITY		kgs	3000	3500	5000	5000	7000	8000
DISTANCE BETWEEN COLUMNS		mm	1200	1200	1600	2000	1600	2000
DISTANCE FROM SPINDLE NOSE TO TABLE		mm	250-1010 / 355-1115		250-1010(250-1250) / 145-905(145-1145)			
SPINDLE TAPER TOOL SHANK			ISO NO. 50(40) BT-50, CAT-50, DIN 69871 (BT-40, CAT-40)					
SPINDLE SPEED RANGE		rpm	20-4000(30-6000)(100-10000)(80-8000)					
MAIN MOTOR OUTPUT (30MIN RATING/CONT.)		HP	25/20(30/25)			25/20(30/25)(35/30)		
RAPID TRAVERSE RATE X, Y-AXIS		mm/min	15000(20000)			12000(15000)		
RAPID TRAVERSE RATE Z-AXIS		mm/min	12000(15000)					
CUTTING FEED RATE		mm/min	1-5000(1-8000)					
MINIMUM INPUT INCREMENT		mm/min	0.001					
TOOL MAGAZINE CAPACITY		pcs	(16/20/32/40)					
MAX, TOOL DIAMETER /ADJACENT POCKETS EMPTY		mm	Ø125 / Ø210					
MAX, TOOL LENGTH (FROM GAUGE LINE)		mm	350					
MAX, TOOL WEIGHT		kgs	(18/20)					
TOOL SELECTION METHOD			(ABS - Random Bl)					
TOOL CHANGE TIME (T-T)(APPROX.)		sec.	8(4.5)					
POWER REQUIREMENT		Kva	40(45)					
FLOOR SPACE REQUIREMENT		mm	5300x4000	6200x4000	6300x4400	6300x5600	8300x4400	8300x5600
MACHINE HEIGHT FROM FLOOR LEVEL		mm	4105		4000(4630)			
MACHINE WEIGHT (APPROX.)		kgs	16000	16800	19000	22000	21500	28500
CNC CONTROLLER		mm	Fanuc, Meidas, Siemens, Heidenhain Series etc.					
POSITIONING ACCURACY		mm	JIS B6338 0.01/300, VDI 3441 P0.025					
REPEATABILITY ACCURACY		mm	± 0.003					

• The above specifications are subject to change without prior notice.

SDV-3224H	SDV-4219H	SDV-4224H	SDV-5224H	SDV-5229H
3200	4200	4200	5200	5200
2400	1900	2400	2400	2900
3000x2200	4000x1700	4000x2200	5000x2200	5000x2700
10000	12000	15000	17500	20000
2500	2000	2500	2500	3000
10000(12000)		8000(10000)		
(20/32/40/60)				
45(50)		55(60)		
9400x6200	11400x5700	11400x6200	13800x6200	13800x6700
1250(4830)				
31500	35500	34500	41500	45500
VDI 3441 P0.035				
± 0.006				

SDV-3224	SDV-4219	SDV-4224	SDV-5224	SDV-5229
3200	4200	4200	5200	5200
2400	1900	2400	2400	2900
3000x2200	4000x1700	4000x2200	5000x2200	5000x2700
10000	12000	15000	17500	20000
2500	2000	2500	2500	3000
10000(12000)		8000(10000)		
(16/20/32/40/60)				
45(50)		55(60)		
9300x6100	10900x5600	10900x6100	13800x6100	13800x6600
30000	30500	33000	40000	44000
VDI 3441 P0.035				
± 0.006				

Standard Accessories

1. Lubrication system
2. Glazed window-type splash guard
3. Screw-type chip conveyor
4. Link-type chip conveyor
5. Coolant equipment
6. Spindle oil cooler
7. Z-axis hydraulic balance unit
8. Pneumatic unit
9. Air blow for chip (by m-code)
10. Work lamp
11. Auto power-off
12. M.P.G
13. Program end & alarm lamp
14. RS-232 interface
15. Leveling blocks and bolts
16. Tool kit
17. Maintenance and operation manual
18. Inspection list

Optional Accessories

1. Auxiliary table
2. Nc (rotary table, index table)
3. 16,20,32,40,60 A.T.C magazine capacity
4. Tool presetter
5. Auto tool length diameter measurement
6. Auto touch probe system
7. Linear scale feedback
8. Coolant through spindle system
9. Oil hole tool shank device
10. Coolant nozzle angle remote control
11. Coolant nozzle angle remote control
12. Manual 45°, 90° angle head, universal Head, extension head.
13. Spindle thermal compensation
14. Available with different spindle spec. & Rpm
15. (Aac) 90° angle head, swing divided Angle head index in c-axis (available 4,8,12,24,72 Position). Extension head (360, 560 Mm). (For sdv-h series only)

Notes

1. () Description is optional accessories.
2. To research and improve our company keep the right of changing design and structure at any time, this data is just for reference.
3. Customer-made machines are available.

w w w . d u g a r d . c o m



European headquarters for Eagle CNC Machine Tools

DUGARD.com

Web.dugard.com Email: info@dugard.co.uk Tele: +44(0)1273 732286